

THE MODEL WORLD AT YOUR FINGERTIPS

# MECCANO MAGAZINE

THE MODEL WORLD AT YOUR FINGERTIPS

1 ADVERT  
CUT OUT

SEPTEMBER 1966 TWO SHILLINGS

**BIG MODEL  
JET PLANS**

**MECCANO CLOCK**

**ALBATROS  
SCALE PLANS**

**MAKE A SLIDE RULE**

**EUSTON'S YESTERDAY**

AVIATION PLASTIC MODELLING AEROMODELLING BOATS RAILWAYS RACEWAYS SCIENCE CYCLING PUZZLES COMPETITIONS



# MAKE A SLIDE RULE FOR A SHILLING

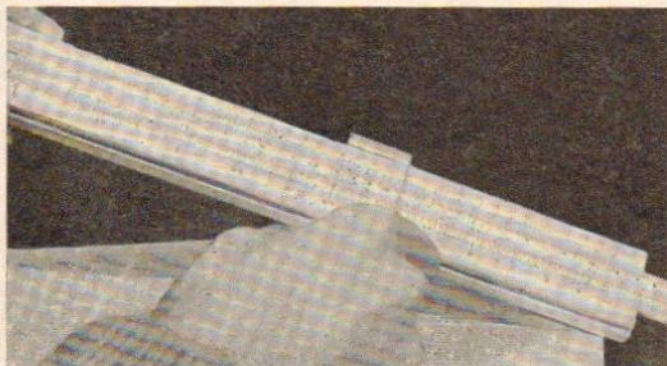

Here's a precision instrument you can make for a shilling or less, using balsa wood and the printed scales reproduced alongside. And construction time is only a matter of an hour or so!

As a special offer you can also obtain a set of printed balsa scales by arrangement with Solarbo Ltd (see their advertisement on page 22). These printed balsa scales should be ordered direct from Solarbo Ltd, Commercial Way, Lancing, Sussex. Enclose a 6d Postal Order and ask for a set of scales for the Balsa Slide Rule

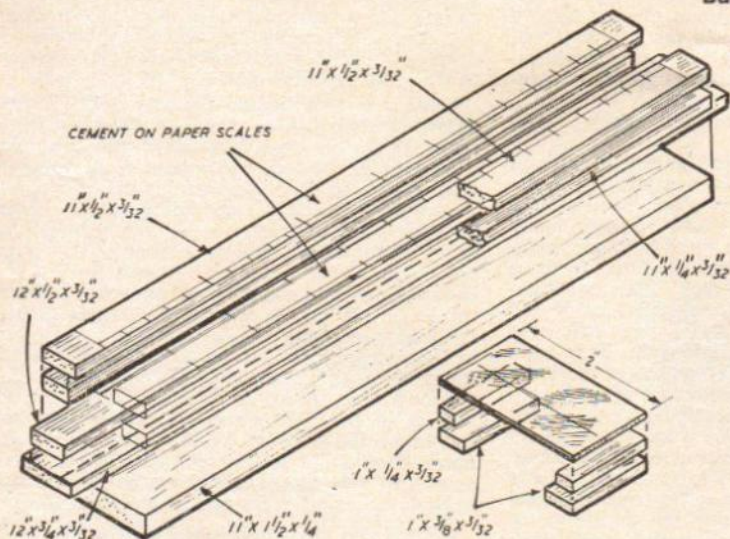

## CUTTING LIST

The slide rule body and slide parts are cut from  $\frac{3}{32}$ " thick balsa sheet, plus a piece of  $\frac{1}{4}$ " balsa sheet for the base.

From the  $\frac{3}{32}$ " sheet cut:-

one piece  $12" \times \frac{3}{8}"$

one piece  $12" \times \frac{1}{2}"$ \*

two pieces  $11" \times \frac{1}{4}"$ \*

two pieces  $11" \times \frac{1}{2}"$ \*

two pieces  $1" \times \frac{1}{4}"$ \*

two pieces  $1" \times \frac{3}{8}"$ \*

From the  $\frac{1}{4}"$  sheet cut:-

one piece  $11" \times 1\frac{1}{2}"$ .

\*Note: if making the slide rule from the PRINTED Balsa Scales available from Solarbo Ltd, these pieces are *not* required.

## ASSEMBLY

The correct stages in assembly are shown in the diagrams below. First make the slide by cementing the  $12" \times \frac{1}{2}" \times \frac{3}{32}"$  piece to the centre of the  $12" \times 2" \times \frac{3}{32}"$  piece.

Lay the slide on the  $11" \times 1\frac{1}{2}" \times \frac{1}{4}"$  base piece and cement the two  $11" \times \frac{1}{4}" \times \frac{3}{32}"$  strips each side. Hold temporarily with pins and check that these permit easy movement of the slide. Remove the slide so that it cannot stick and leave to set.

Replace the slide in position and use it as a guide to cement the two top strips in place on the body. When you are satisfied that you have got a snug but easy fit, hold with pins and withdraw the slide completely. Leave until set.

Replace the slide once more and position it centrally in the body—i.e. overlapping  $\frac{1}{8}"$  at each end. Cut out the paper scales and cement to the top of the body and slide. Leave for a few minutes to set and then separate carefully along the thicker lines to free the slide, using a very sharp modelling knife or razor blade.

It is advisable to use a metal straightedge to guide the blade when making these two cuts.

In order to use the slide rule, a sliding cursor is needed. This consists of a piece of  $2" \times 1"$  heavy celluloid or acetate sheet cemented to the balsa slide pieces as shown in the exploded view. A line is scribed on the celluloid at exactly right angles to the direction of travel. The cursor should be an 'easy' sliding fit, with as little side play as possible.

That completes the slide rule, ready for use. To make the slide move easily it is recommended that it is rubbed lightly with the end of a candle along the edges which locate in the body. The paper scales can be protected if desired, by covering with clear cellulose tape or a coating of clear paper varnish.

Note: when using the printed balsa scales, assembly follows the same procedure except that the slide top and the two top strips for the body are cut from the printed balsa panel. Stages 6 and 7 are not required since the scales are already printed in position.

